



AC Hour Meter

Series T50

Main Features:

The Series T50 electronic AC hour meter is a low-cost, reliable hour meter incorporating the latest state-of-the-art electronics. It's quartz-crystal time base insures accurate long term time-keeping.

A reliable electromechanical wheel-type indicator is used to store accumulated hours.

This compact, tamper-proof meter is sealed against the environment to provide years of service.

The T50 elapsed time indicator was designed for use on test and recording equipment, for providing maintenance control, for establishing warranty programs, for measuring machine utilization and production time, or for any application where time-in-use is to be determined.

- Solid state electronic circuit
- Quartz-crystal for accurate timing
- Absolutely will not lose count
- Variety of mounting types available: panel, 3-hole panel, square panel, 4-hole square
- AC Voltages from 24-230V,AC
- High impact, tamperproof plastic case
- Sealed case protects against moisture and dirt
- UL and CSA recognized
- Indicates operating time in hours and tenths
- Frequency insensitive design
- Optional gasket complies to NEMA 4X and 12
- Made in the USA



General Specifications

Time Scale	6 digits 99,999.9 Hours Automatic recycle to zero
Figures	Hours -- white on black Tenths -- red on white Digit height: 0.140"
Operating Voltages	230V,AC; 115V,AC, 24V,AC $\pm 10\%$ Other voltages available
Dimensions	1.68" W x 1.68"H x 1.26" D Face diameter (flange): 2.8" Face diameter (cutout): 2.0"
Frequency	50Hz or 60Hz
Power Consumption	less than 0.4 watts
Accuracy	Better than $\pm 0.02\%$ over entire length
Temperature	from -22°F to 149°F (-30°C to 65°C)
Vibration Resistance	Withstands 10 to 75Hz at 1 to 8 G's
Termination	1/4" male blade terminals
Configuration	Round, 3-hole bezel Round, SAE bezel with new push-on retaining ring
Approvals	UL and CSA recognized

AC Hour Meter Series T50



PC&S products are manufactured under a total quality system that provides total engineering integrity. Products have been engineered to satisfy specifications, performance, reliability and life cycle to exacting standards.

PC&S strives to meet customer requirements and exceed expectations. We do this through monitoring and measuring our process and product, customer satisfaction, internal auditing, analysis of production data, continual improvement including corrective and preventative action. Our quality management systems are certified in accordance with ISO 9001:2008 standards.

Part Numbers		
Part Number	Display	Voltage
T50B1	6-digit	230V,AC
T50B2	6-digit	115V,AC
T50B4	6-digit	24V,AC
with NEMA 4X,12 Gasket:		
T50B212	6-digit	115V,AC
T50B112	6-digit	230V,AC

Dimensional and Wiring Diagrams

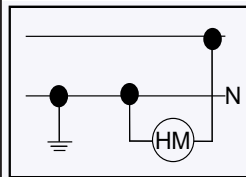
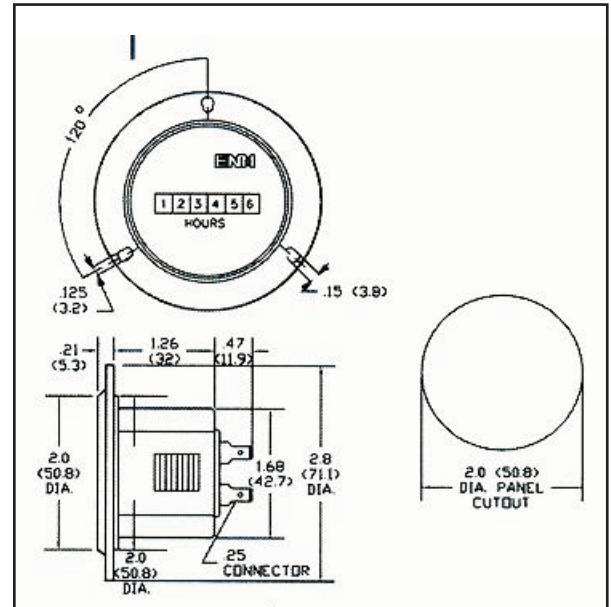

Single-phase 120V System: 2-wire

Connect one terminal to power wire; connect the opposite terminal to neutral wire

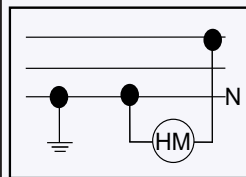

Single-phase 120V/240V System: 3-wire

Connect one terminal to power wire; connect the opposite terminal to neutral wire

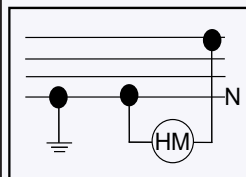

Three-phase 120V/208V System: 4-wire

Connect one terminal to any one power wire; connect the opposite terminal to neutral wire

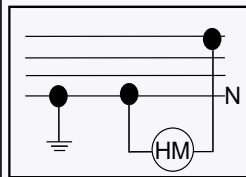

Three-phase 120V/240V System: 4-wire Delta with a high leg

Connect one terminal to any of two available 120V power wires; connect the opposite terminal to neutral wire.

The hour meter is not to be connected to the high leg.



PANEL COMPONENTS & SYSTEMS, INC.
MAIN OFFICE: Tel.: (973) 448-9400 Fax: (973) 448-1674
 149 Main Street, Stanhope, NJ 07874

Your Local PC&S Distributor:

Additional Offices:

South East: Charlotte, NC Phone: (704) 535-3357
 South Central: Tulsa, OK Phone: (862) 258-6974
 Canada: Edmonton, AB Phone: (877) 962-0557